

10'

10'

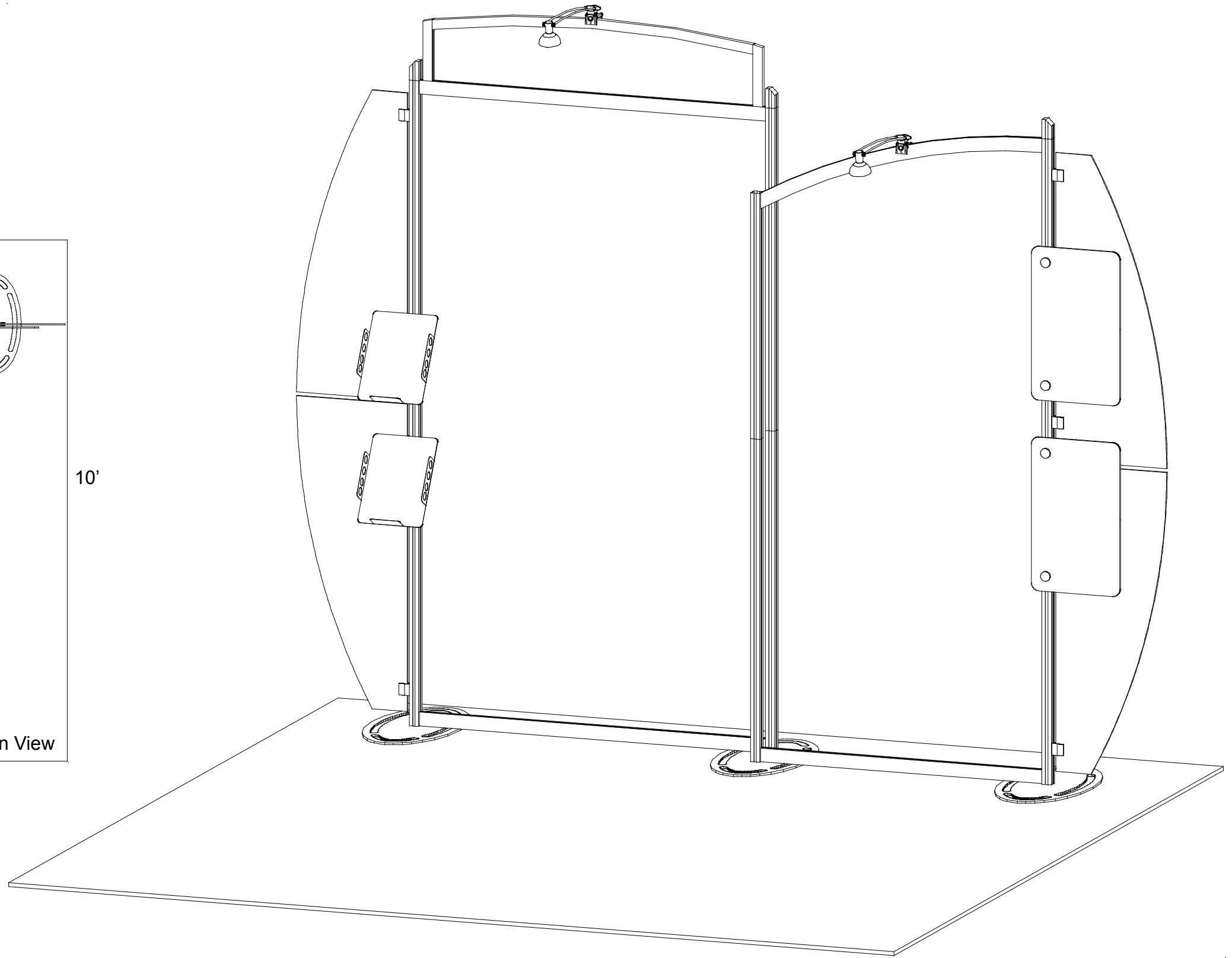

WHEN DISASSEMBLING ALUMINUM EXTRUSION, TIGHTEN ALL SETSCREWS AND LOCKS TO PREVENT LOSS DURING SHIPPING

visionary™ DESIGNS

Using Your Setup Instructions

The Visionary Designs Setup Instructions are created specifically for your configuration. They are laid out sequentially, including an exploded view of the entire display, and then a logical series of detailed steps to assemble the main structure and components. We encourage you to study the instructions **before** attempting to assemble your exhibit.

Each page reminds you to tighten the setscrews after disassembling your exhibit to prevent loss of the locks and setscrews (see below in RED). This is VERY IMPORTANT.

Cleaning and Packing Your Display

- 1) Use care when cleaning aluminum extrusion or acrylic inserts. Use only non-abrasive cleaners.
- 2) When cleaning laminate inserts or countertops, use mild cleansers and a soft material such as cotton.
- 3) Keep all display components away from extreme heat and long exposure to sunlight to avoid warping and fading.
- 4) Retain all packing material. It will make re-packing much easier and will reduce the likelihood of shipping damage.



The Tool

Most Visionary Designs exhibits can be assembled with the supplied Hex Key Tool. Occasionally, a flat head screwdriver may be required.



Typical Connection

Most horizontal extrusion connections have a patented expandable lock. This lock inserts into the groove of an opposing extrusion. Tightening the lock with the Hex Key Tool expands the lock and creates a strong positive connection.



Typical Connection (cont'd)

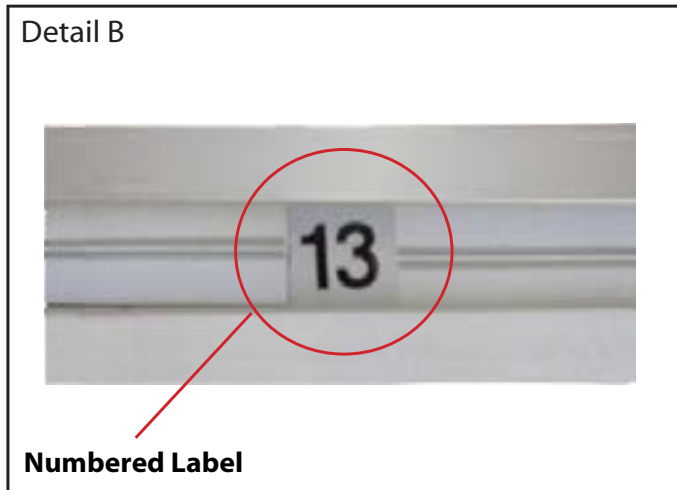

Detail B

Numbered Label

Each extrusion contains a numbered label which corresponds with setup instructions. The label is located within a groove of the extrusion (when possible). With Visionary Designs the labels contain Black numbers unless otherwise specified.



Detail C

Horizontal Inline Connection (remove only one setscrew)

Remove only (1) setscrew when disassembling. Replace setscrew in extrusion after assembling it. Before packing, replace setscrew in extrusion to avoid losing it.

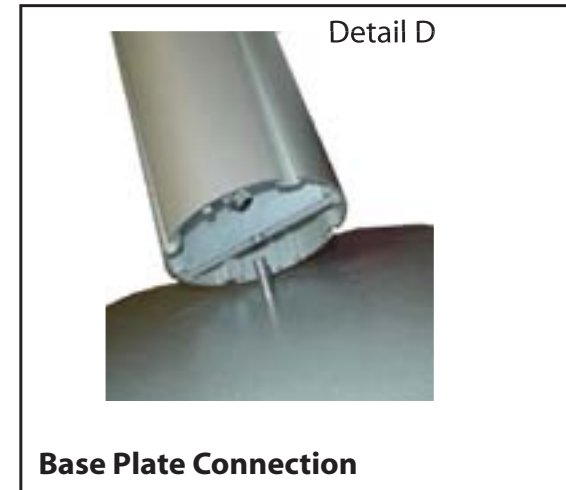

Detail D

Base Plate Connection

Attach base plate to round or square vertical extrusion using the bolt provided. Be careful not to strip the threads.

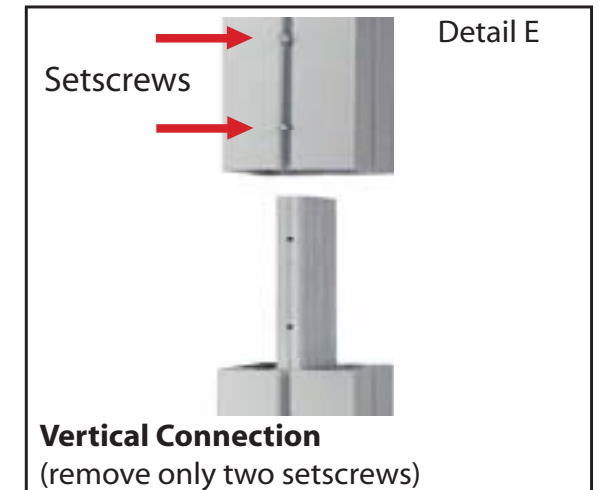

Detail E

Vertical Connection
(remove only two setscrews)

When vertical extrusions are packed in portable cases rather than crates or tubs, they must be broken down into smaller sections which then require assembly.

Remove only (2) setscrews when disassembling. Replace setscrews in extrusion after assembling it. Before packing, replace setscrews in extrusion to avoid losing them.

WHEN DISASSEMBLING ALUMINUM EXTRUSION, TIGHTEN ALL SETSCREWS AND LOCKS TO PREVENT LOSS DURING SHIPPING

Item	Qty.	Description
1	2	Base Plate w/ 1 Hole
1a	1	Base Plate w/ 2 Holes
2	1	42”h Lower Square Vertical Extrusion
3	1	42”h Upper Square Vertical Extrusion
4	1	42”h Lower Square Vertical Extrusion
5	1	42”h Upper Square Vertical Extrusion
6	1	42”h Lower Square Vertical Extrusion
7	1	32”h Upper Square Vertical Extrusion
8	1	42”h Lower Square Vertical Extrusion
9	1	42”h Upper Square Vertical Extrusion
10/10a	1/1	47”w Horizontal Extrusion
11	1	38.25”w Horizontal Extrusion
12	1	40.9826” Curved Extrusion
14	1	4” Stabilizing Extrusion

Steps:

- 1) Attach vertical extrusions [2,4,6,8] to base plates [1,1a].
- 2) Attach upper vertical extrusions [3,5,7,9] to lower extrusions [2,4,6,8] using connection bar [b].
- 4) Connect stabilizing bar [14] between verticals [5,7], refer to detail.
- 5) Attach horizontal extrusions [10,10a,11,12] between vertical assemblies as shown.
- 6) Apply graphic to back of assembled backwall.

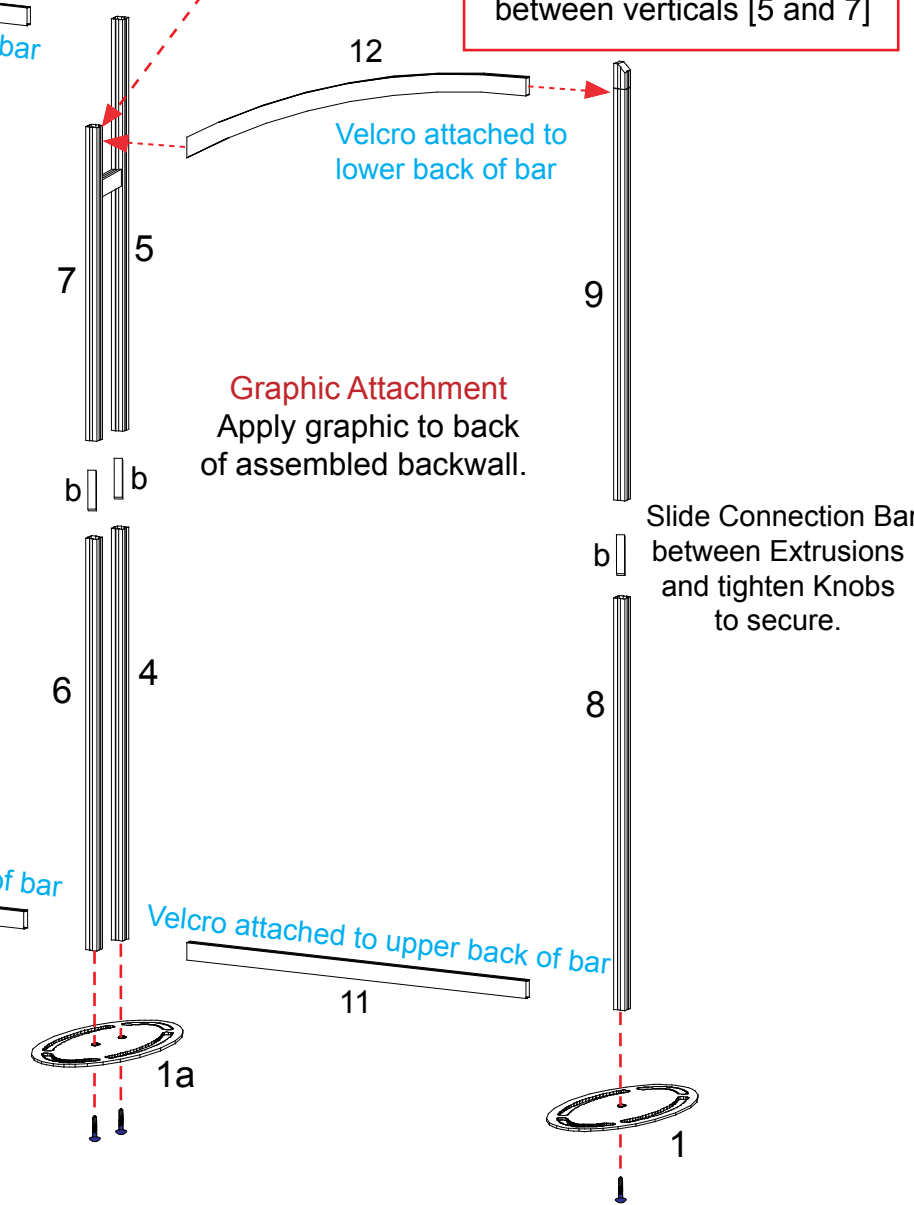
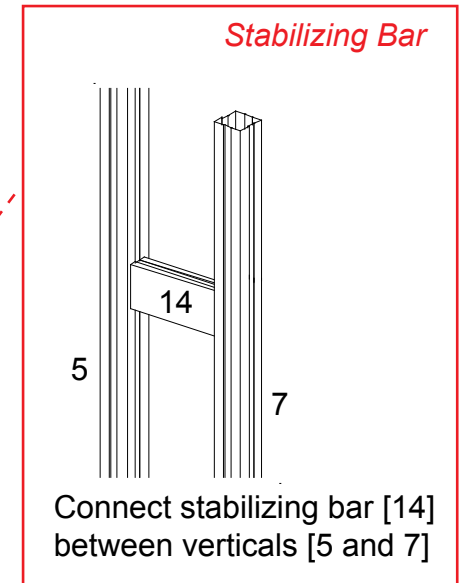
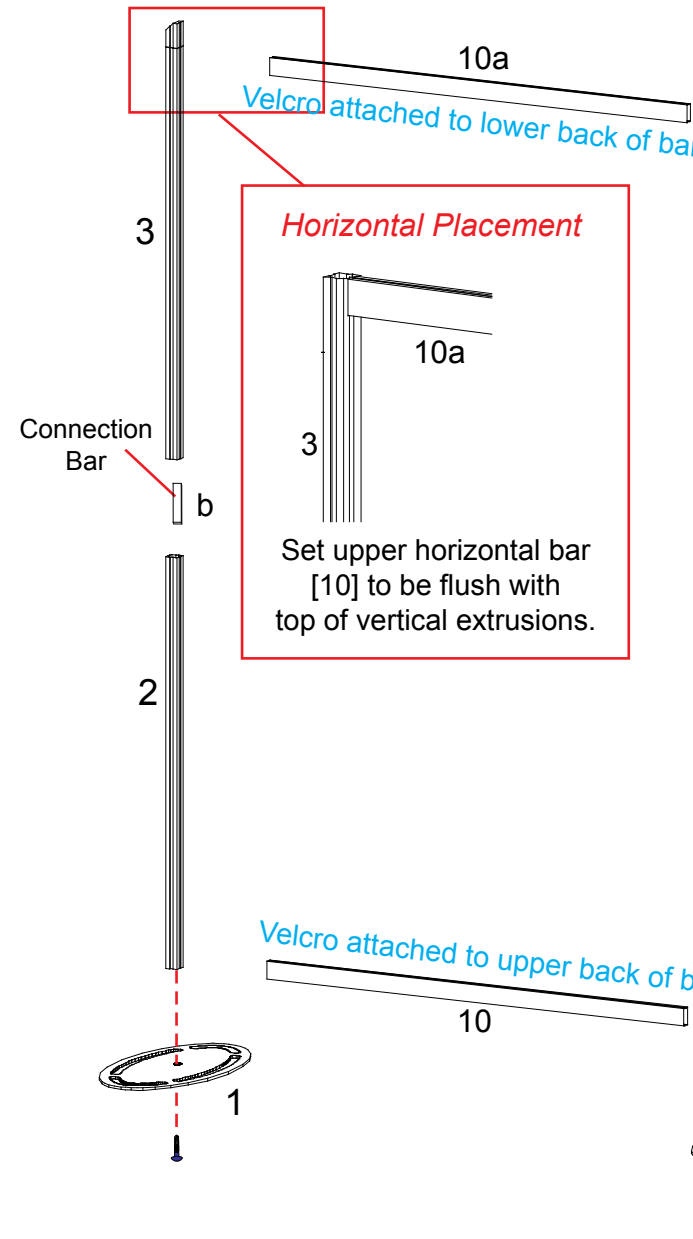
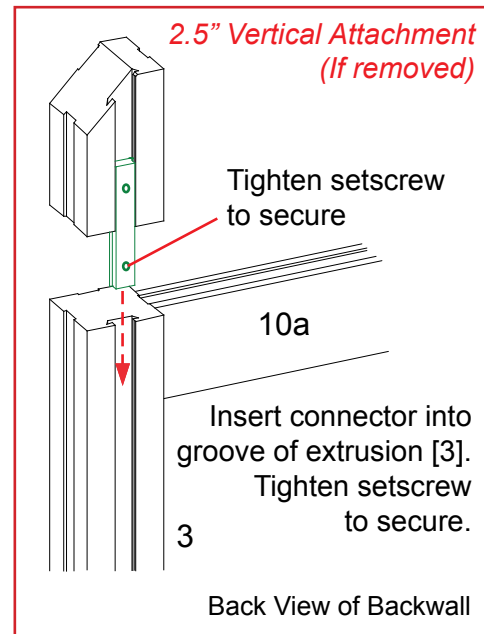

STAR indicates location of knobs on BACKSIDE of unit.

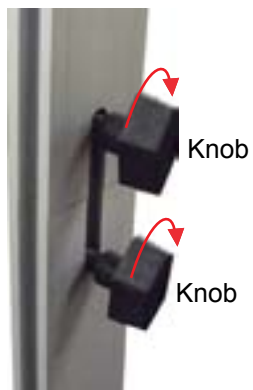

Turn Knob Clockwise to Tighten Lock

Do not over tighten Knobs.

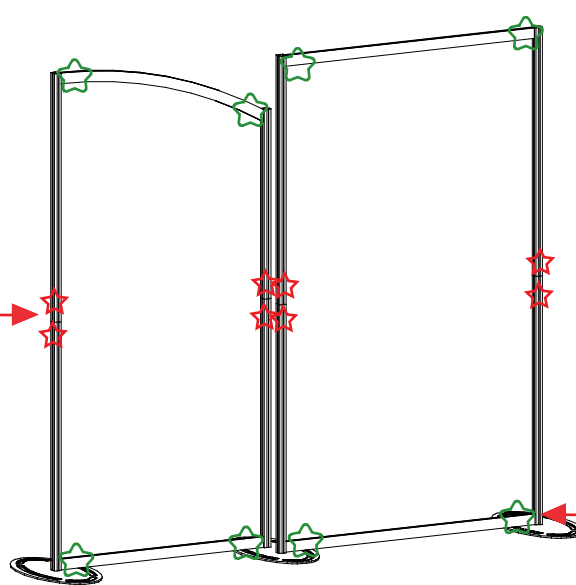

GREEN STAR indicates location of connection lock with knob.



WHEN DISASSEMBLING ALUMINUM EXTRUSION, TIGHTEN ALL SETSCREWS AND LOCKS TO PREVENT LOSS DURING SHIPPING

866.652.2100

Steps:

- 1) Attach assembled header frame to top of backwall as shown.
- 2) Apply graphic to velcro on back of header frame.
- 3) Attach lights to header frame and backwall as shown.
- 4) Attach wings to backwall with A10 clamps.
- 5) Attach literature racks to backwall as shown.
- 6) Attach rectangular graphics to backwall with screw caps.

Item	Description
15	9.2856" h Vertical extrusion
16	9.2856" h Vertical extrusion
17	43.66" w Curved Horizontal Extrusion

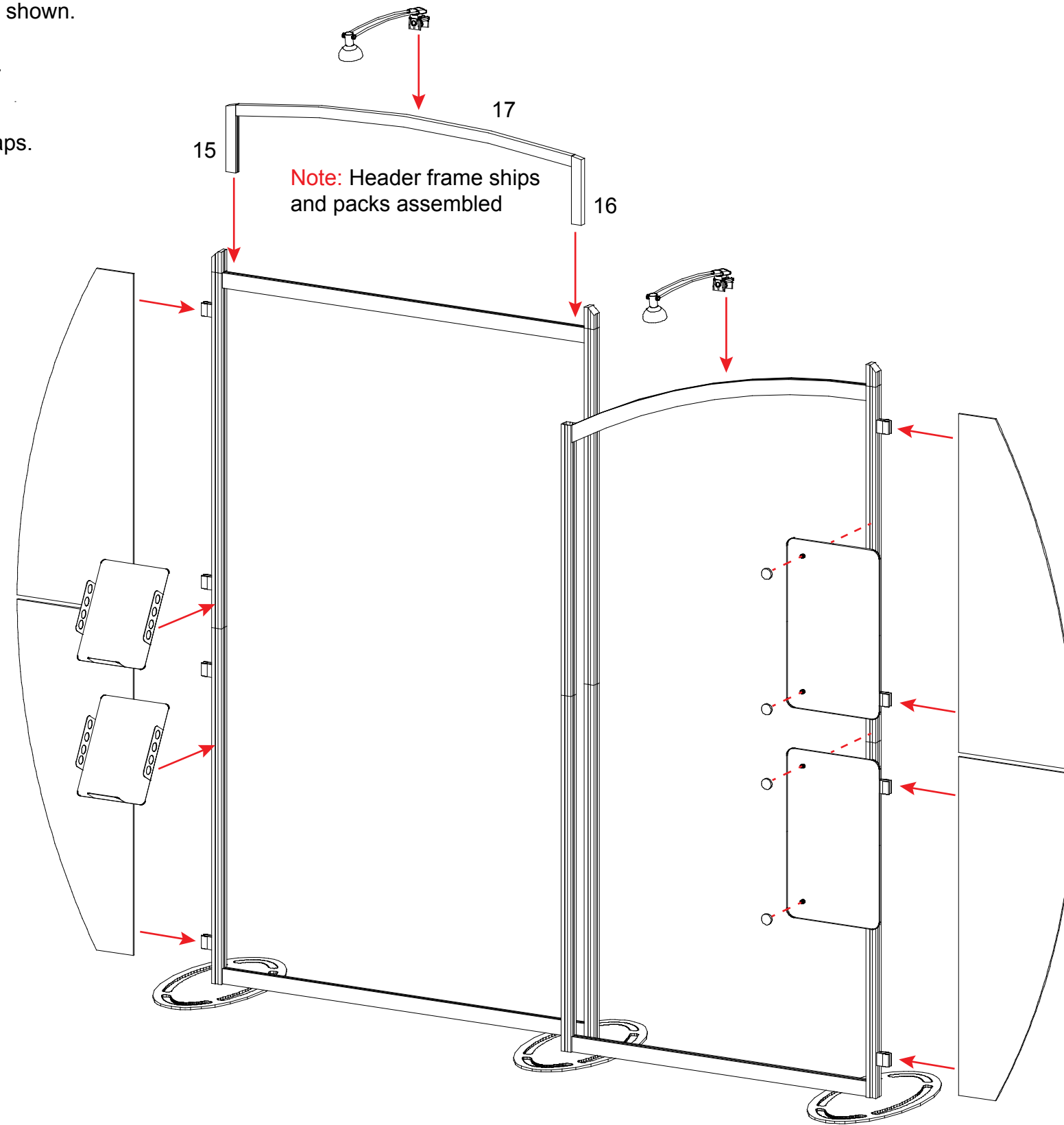
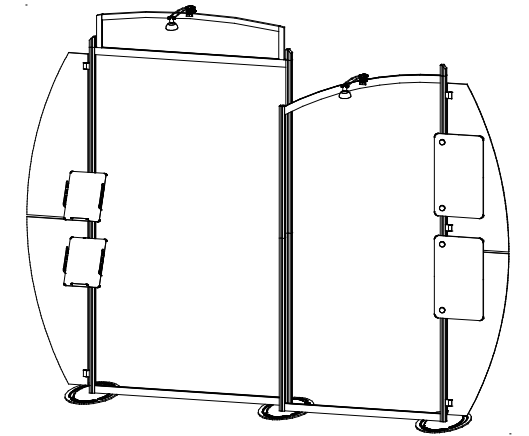

Note: Header frame ships and packs assembled

Literature Rack Attachment

Tighten Lock to Secure

Attach connector piece to rack as shown. Then connect assembled literature rack to vertical extrusion.

A10 Clamp Detail

Tighten set screw to secure A10 to extrusion.

Tighten knob to secure graphic header in place.

WHEN DISASSEMBLING ALUMINUM EXTRUSION, TIGHTEN ALL SETSCREWS AND LOCKS TO PREVENT LOSS DURING SHIPPING

Top View

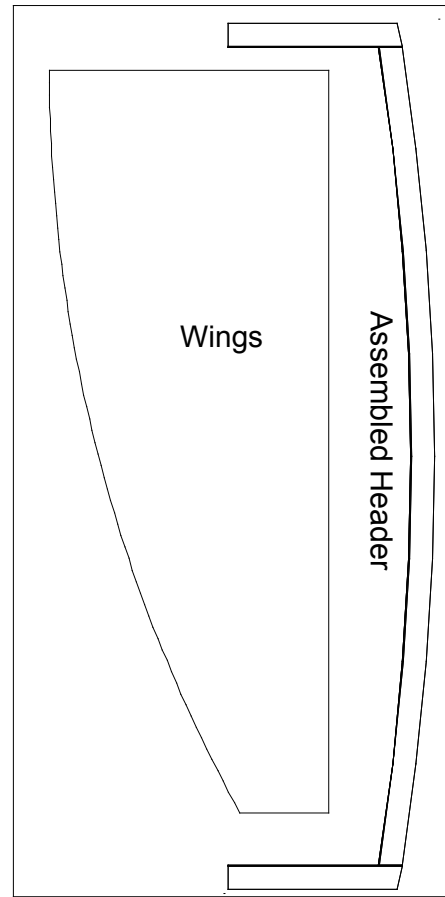

Level 1

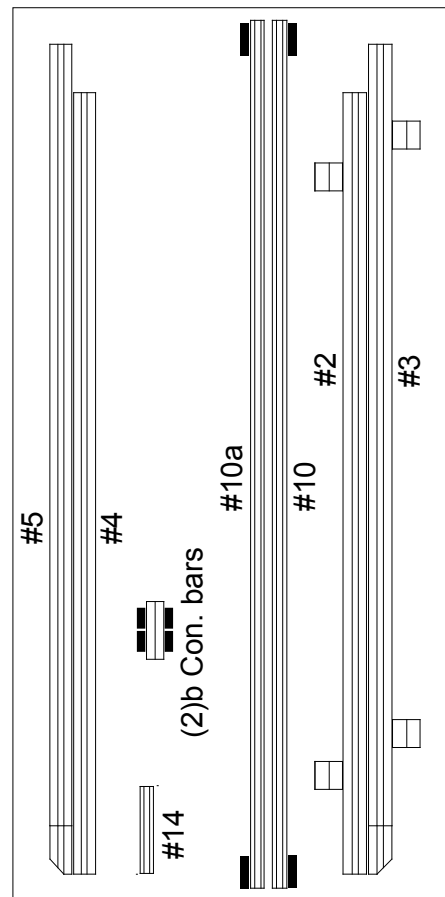

Level 2

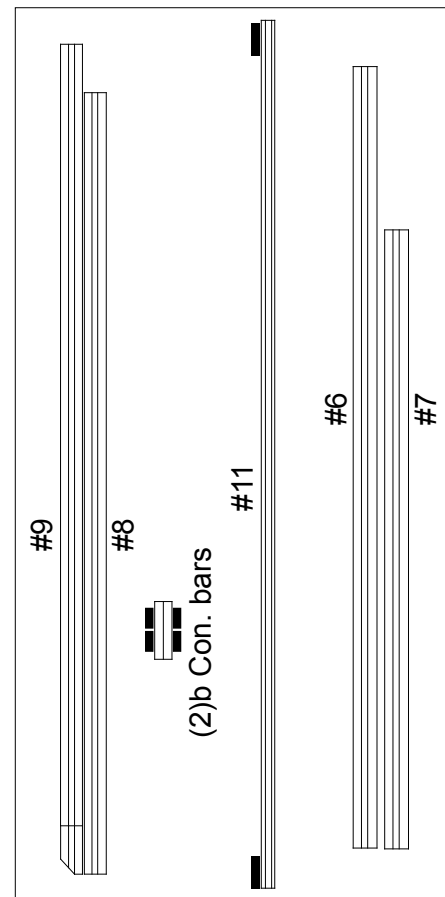

Level 3

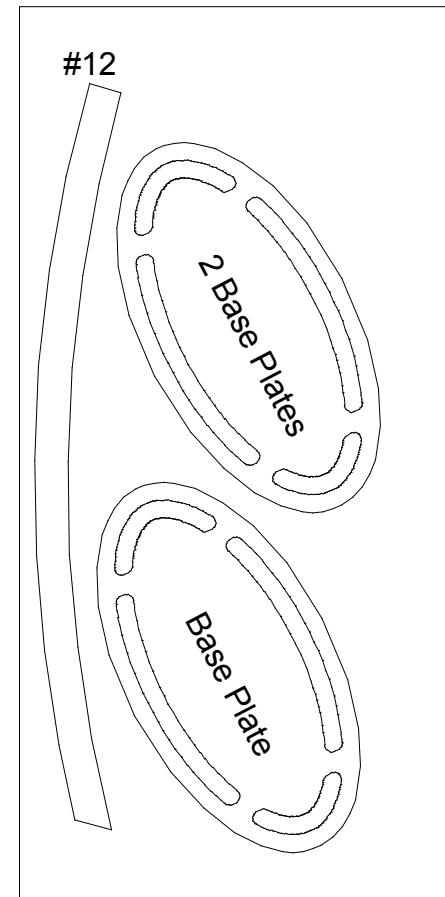

Level 4

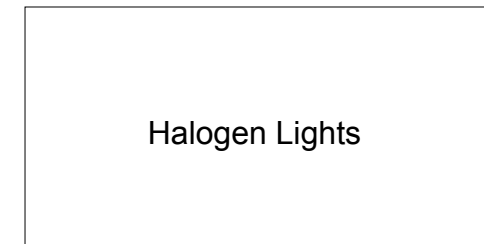
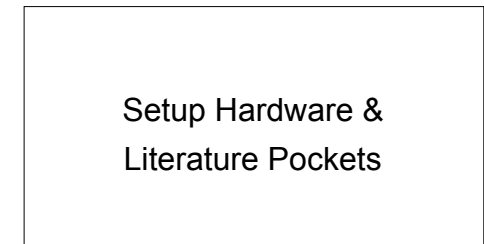
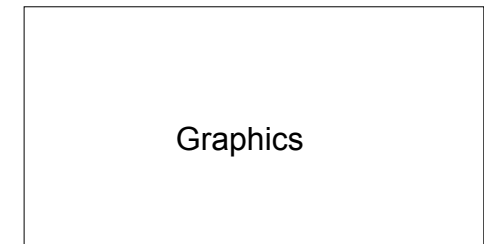

WHEN DISASSEMBLING ALUMINUM EXTRUSION, TIGHTEN ALL SETSCREWS AND LOCKS TO PREVENT LOSS DURING SHIPPING